

# B-TOO™ DRILLING & TAPPING MACHINE

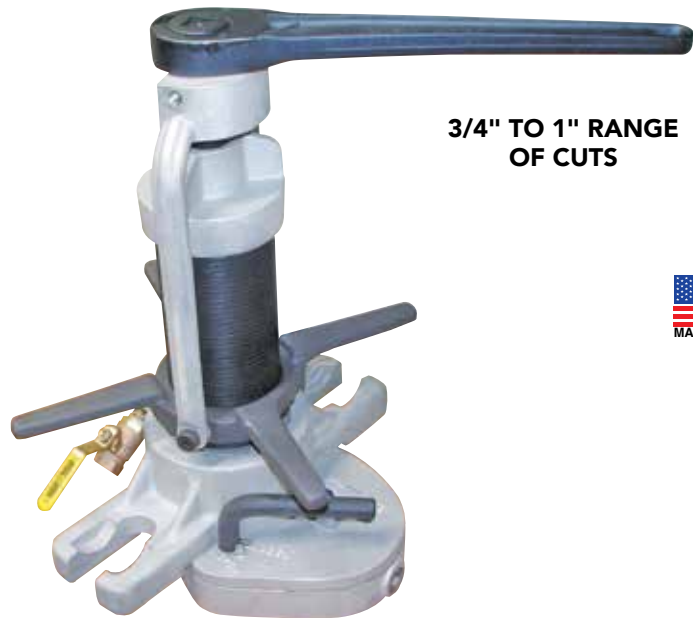

## MATERIAL SPECIFICATIONS

- Powered by hand or with Ridgid 690-l.
- High strength, modular aluminum and steel components.
- Inserts any 3/4" to 1" corporation stop under pressure.
- Extracts threaded corporation stops from the main and inserts a main plug.
- Uses Mueller B101 saddles, drill/taps, ratchets, chain holders, chains and screw plugs.



**3/4" TO 1" RANGE OF CUTS**



### SHORT COMPACT DESIGN

Provides greater stability when cutting with the drill tap and easier alignment when inserting the corporation stop.

Can be used on water pressures up to 250 psi without additional fittings or components.

ITEM NUMBER	DESCRIPTION	LIST PRICE
<b>356-00</b>	<b>B-Too Tapping Machine for Direct Insertion</b>	<b>\$7,270.74</b>
353-60-32	1/4" Hex Wrench	included
353-10-1	Tapping Compound	included
356-61	Tool Box	included

*see pages TM-16 and TM-17 for complete list of components*

#### TO ORDER:

1. Order B-Too Drilling Machine.
2. Order Drill/Taps per desired tap size, thread type and pipe type. Drill/Tap corresponds to body inlet threads on corporation stop.
3. Order Quick Release Screw Plugs with threads matching the body outlet threads of the corporation stops used. See chart to match screw plugs to bodies. (see page TM-17).
4. Order a pipe saddle for each size of pipe the B-Too will be used on. One extra chain section (Item Number 356-11) required for 18"– 30" mains, two extra chain sections required for 32"– 48" mains.
5. Order Power Unit if desired.
6. Order extra Tapping Compound if needed (see pg. TM-30).

TRANSMATE



# B-TOO™ DRILLING & TAPPING MACHINE

**THE RUGGED, LIGHTWEIGHT B-TOO™  
MAKES DRILLING AND TAPPING A PIPE AS  
SIMPLE AS THESE STEPS...**

**LOAD DRILL TAP**

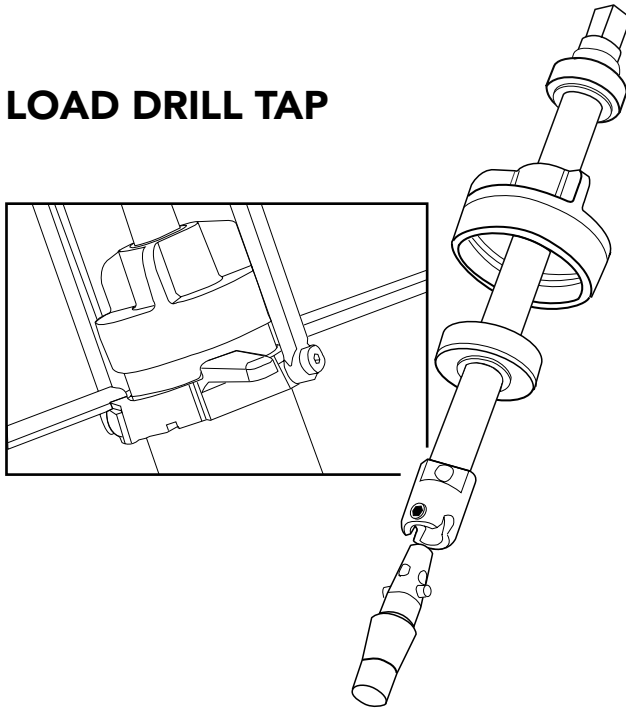

**MOUNT ON PIPE**

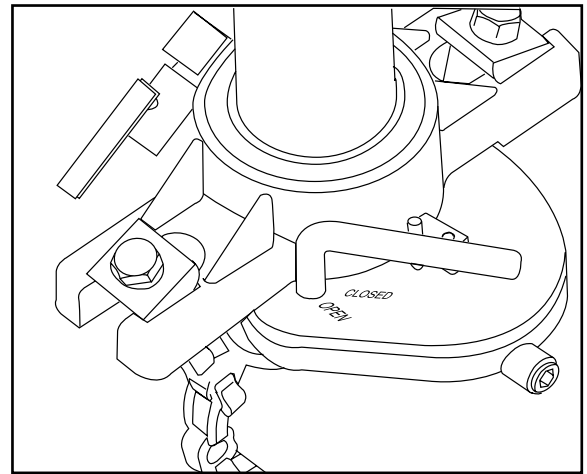

**DRILL / TAP**

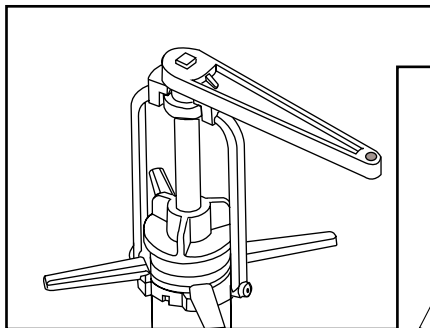

**PREPARE CORPORATION  
STOP AND INSERT**

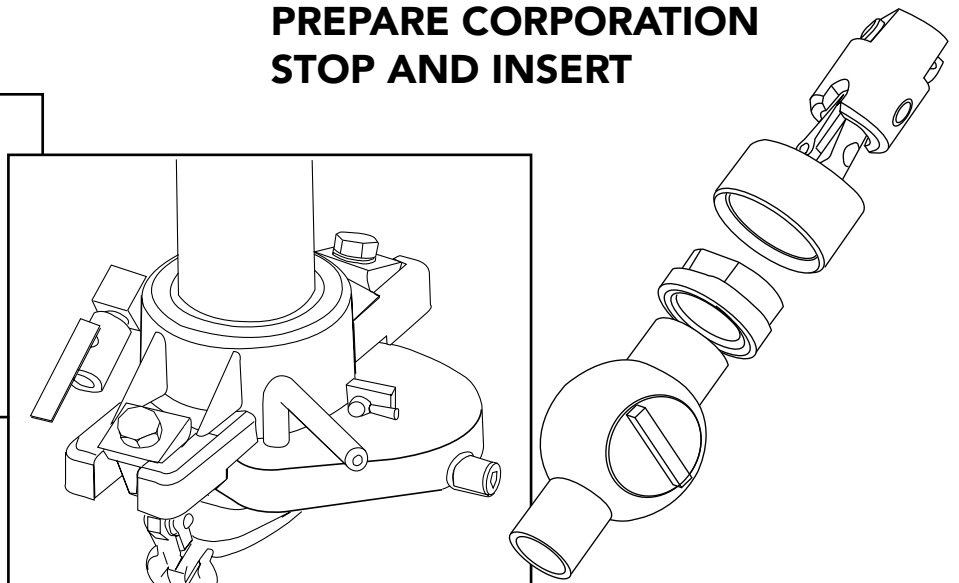

# B-TOO™ DRILLING & TAPPING MACHINE

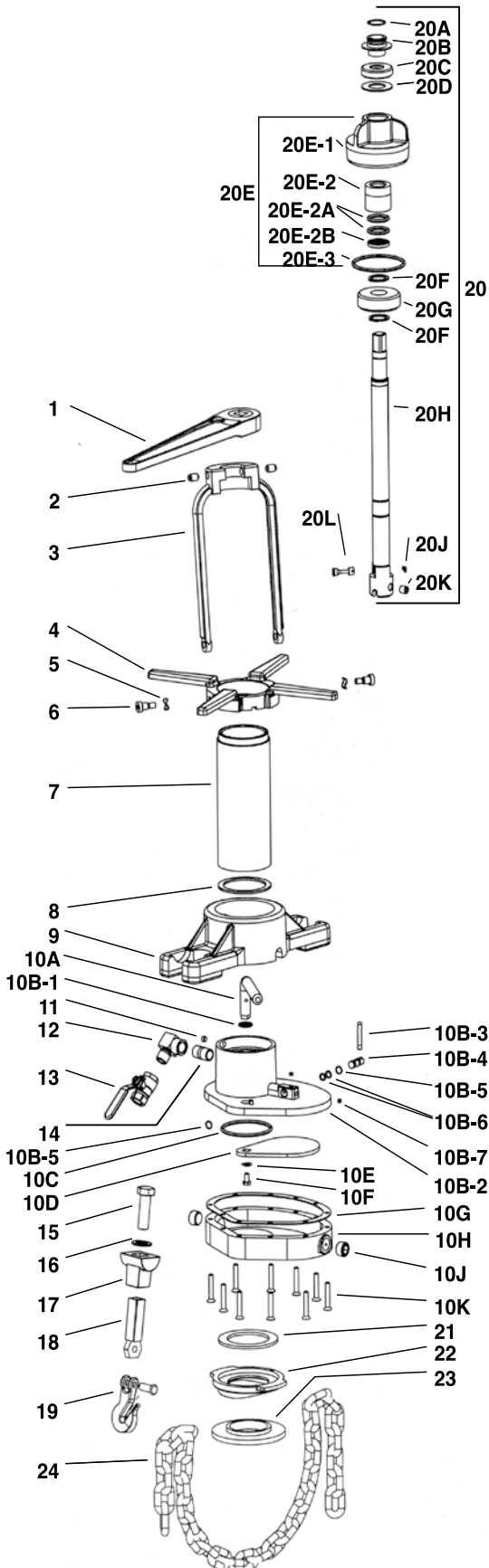

REF. NO.	ITEM NUMBER	DESCRIPTION	LIST PRICE
1	356-19	Ratchet Wrench (13/16")	\$499.87
2	356-06-02	Yoke Plunger, Vlier Std. (2 req'd)	ea. 28.84
3	356-06	Yoke	287.61
4	356-07	Feed Nut	278.50
5	356-06-03	Yoke Bolt Washer (2 req'd)	ea. 9.21
6	356-06-01	Yoke Bolt, 1/2" x 1/2" socket (2 req'd)	ea. 9.07
7	356-05	Barrel	346.14
8	356-08-03	Gasket, Slide Gate to Barrel	27.94
9	356-12	Clamp	331.45
10	356-01A	Slide Gate Assembly	1,455.71
10A	356-02	Slide Gate Disk Handle	213.90
10B	356-03A	Slide Gate Top Assembly	850.15
10B-1	356-02-01	Slide Gate Handle O-ring	6.46
10B-2	356-03	Slide Gate Top	561.04
10B-3	356-20-10	By-Pass Valve: 1/4" Spool Lever	54.80
10B-4	356-20-1	By-Pass Valve: 1/4" Spool	120.90
10B-5	356-20-09	By-Pass Valve: 1/4" Spool Retaining Ring (2 req'd)	ea. 2.88
10B-6	356-20-08	By-Pass Valve: 1/4" Spool O-ring	2.21
10B-7	356-03-01	Slide Gate Top Plug 1/16" NPT Plug (2 req'd)	ea. 2.21
10C	356-04-01	Slide Gate Disk O-ring (2 req'd)	6.88
10D	356-04	Slide Gate Disk	197.07
10E	356-04-03	Disk Handle Washer	9.36
10F	356-04-04	Slide Gate Disk Screw	2.21
10G	356-08-02	Gasket Slide Gate	72.69
10H	356-01	Slide Gate Bottom	448.50
10J	356-01-04	Slide Gate Bottom Plug (2 req'd) 3/4" NPT	ea. 5.54
10K	356-03-05	Slide Gate Screw (10 req'd)	ea. 2.21
11	356-03-03	Slide Gate Top to Barrel Set Screw	2.21
12	356-03-04	Exhaust Elbow	30.45
13	371-02	Exhaust Valve	40.91
14	356-01-03	Slide Gate Pipe Nipple	3.86
15	356-14-02	Swivel Bolt for Rd. Link Chain (2 req'd)	ea. 10.61
16	8FW-Z12	Zinc Plated Washer 3/4" (2 req'd)	ea. 1.78
17	356-15	Hook Holder (2 req'd)	ea. 103.86
18	356-16	Hook Link (2 req'd)	ea. 133.57
19	356-11-01	Round Link Chain Hook (2 req'd)	ea. 41.84
20	356-10A	Holder Assembly	1,541.96
20A	356-21	Spiral Snap Ring	11.09
20B	356-17	Stop Collar	148.02
20C	355-56	Thrust Bearing	74.21
20D	356-18	Shaft Support Thrust Washer	103.86
20E	356-08A	Cap Assembly	406.49
20E-1	356-08	Cap only	294.85
20E-2	356-09A	Holder Bushing Assembly	129.47
20E-2a	356-09-01	Holder Bushing O-ring (2 req'd)	ea. 2.21
20E-2b	356-09-02	Holder Bushing Wiper	29.04
20E-3	356-08-01	Cap O-ring	3.31
20F	350-20-54	Shaft End Snap Ring (2 req'd)	ea. 21.18
20G	356-13	Holder Guide	76.27
20H	356-10	Holder	839.36
20J	353-11-506	Holder Cotter Pin	2.55
20K	353-11-514	Holder Socket Head Set Screw	3.86
20L	353-11-505	Holder Knockout Pin	89.19
21	356-08-04	Top Saddle Gasket	28.62
22	356-23-xx	B-Too Saddle xx Mueller Style (See following page)	
23	353-57-084	4" Bottom Saddle Gasket for 4" and larger	84.23
	353-57-083	3" Bottom Saddle Gasket, (Not Included)	37.20
	353-57-082	2" Bottom Saddle Gasket, (Not Included)	64.47
24	356-11	Chain, Round Link	119.35
Not Illustrated:			
	353-60-32	1/4" Hex Wrench	33.27
	353-10-1	Tapping Compound	56.44
	356-61	Tool Box	1,033.78

TRANSMATE



# B-TOO™ DRILLING & TAPPING MACHINE PARTS LIST

ITEM NUMBER	DESCRIPTION	LIST PRICE
<b>PVC Drills and Taps (requires both Cutter and Tap)</b>		
355-01-210	Cutter, PCV 3/4": 5957 (AWWA CC thread)	\$518.65
353-04-206	Tap, 3/4" PVC: 5956 (AWWA CC thread)	1,074.86
353-01-206	Cutter, 1" PVC: 5975-1 (AWWA CC thread)	519.88
353-04-208	Tap, 1" PVC: 5956 (AWWA CC thread)	1,160.55
353-03	Drill Tap Roll Pin	3.26
<b>DRILL/TAPS</b>		
<b>For Ductile, Cast Iron &amp; A/C</b>		
353-02-106	Drill/tap, 3/4" IP: 5951 (IP thread)	761.17
353-02-108	Drill/tap, 1" IP: 5951 (IP thread)	807.31
353-02-206	Drill/tap, 3/4" CC: 5950, 5952 (AWWA thread)	538.68
353-02-208	Drill/tap, 1" CC: 5950, 5952 (AWWA thread)	736.53
353-03	Drill Tap Roll Pin	3.26

<b>SCREW PLUGS (other thread forms available upon request)</b>		
<i>Note: Adapter thread description describes thread machined on the adapter</i>		
356-22-01	B-Too, Quick Release Screw Plug Body 1"	\$356.11
356-22-02	B-Too, Quick Release Screw Plug 1" Coarse Thread Compression	356.11
356-22-03	B-Too, Quick Release Screw Plug 1" MIP	281.95
356-22-04	B-Too, Quick Release Screw Plug 1" Drive Thread	281.95
356-22-05	B-Too, Quick Release Screw Plug 1" FIP	281.95
356-22-06	B-Too, Quick Release Screw Plug 3/4" Coarse Thread Compression	281.95
356-22-07	B-Too, Quick Release Screw Plug 3/4" FIP	281.95
356-22-08	B-Too, Quick Release Screw Plug 3/4" MIP	281.95
356-22-09	B-Too, Quick Release Screw Plug 3/4" Drive Thread	
356-22-10	B-Too, Quick Release Screw Plug Body 1-1/4" <sup>1</sup>	415.18
356-22-11	B-Too, Quick Release Screw Plug 1-1/4" Coarse Thread Compression <sup>1</sup>	326.46
356-22-12	B-Too, Quick Release Screw Plug 1-1/4" FIP <sup>1</sup>	326.46
356-22-13	B-Too, Quick Release Screw Plug 1" Fine Thread Compression	281.95
356-22-14	B-Too, Quick Release Screw Plug 3/4" Fine Thread Compression	281.95

<sup>1</sup> For use on 1" Corporations with 1-1/4" outlet threads.

ITEM NUMBER	DESCRIPTION	LIST PRICE
<b>PIPE SADDLES</b>		
356-23-02	*B-Too, Saddle 2" Mueller Style	\$103.86
356-23-03	*B-Too, Saddle 3" Mueller Style	103.86
356-23-04	B-Too, Saddle 4" Mueller Style	103.86
356-23-06	B-Too, Saddle 6" Mueller Style	103.86
356-23-08	B-Too, Saddle 8" Mueller Style	103.86
356-23-10	B-Too, Saddle 10" Mueller Style	103.86
356-23-12	B-Too, Saddle 12" Mueller Style	103.86
356-23-14	B-Too, Saddle 14" Mueller Style	103.86
356-23-16	B-Too, Saddle 16" Mueller Style	103.86
356-23-18	B-Too, Saddle 18" Mueller Style	103.86
356-23-20	B-Too, Saddle 20" Mueller Style	103.86
356-23-24	B-Too, Saddle 24" Mueller Style	103.86

\* must order bottom saddle gasket, see TM-16  
**30"- 60" SADDLES ALSO AVAILABLE**

<b>TAPPING COMPOUND</b>		
353-10-1	Tapping Compound	56.44
353-10-3	Tapping Compound / Case (12)	650.93

<b>POWER OPTION</b>		
373-356	Ridgid 690-I Electric Drive w/ 13/16" sq. drive adapter	5,120.74
370-70	GF-15 Ground Fault Interrupter Plug (required)	219.13

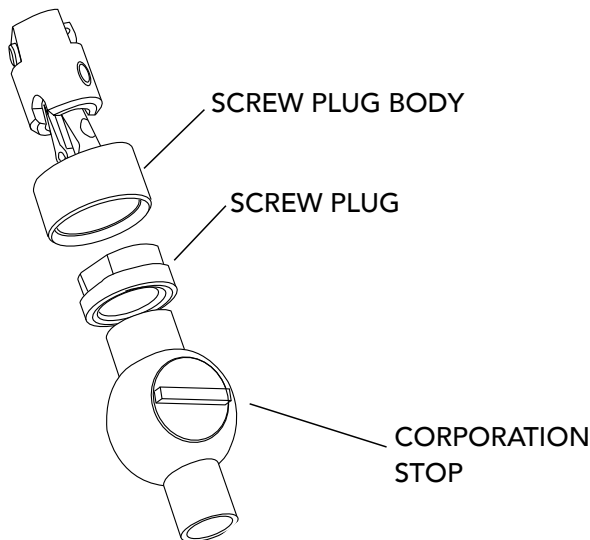

<b>SCREW PLUG CHART *</b>		
BODY SIZE	SCREW PLUGS THAT FIT	
1" Body	1" Compression (356-22-01) 1" MIP 1" Drive Thread 1" Mueller Thread	3/4" Compression 1" FIP 3/4" FIP 3/4" MIP 3/4" Drive Thread 3/4" Mueller Thread
1-1/4" Body	1-1/4" Compression	1-1/4" FIP

\* Corp. Stop Adapter Cross Reference at [www.romac.com/tapmate-too](http://www.romac.com/tapmate-too)

### CUTTING DRILL/TAPS

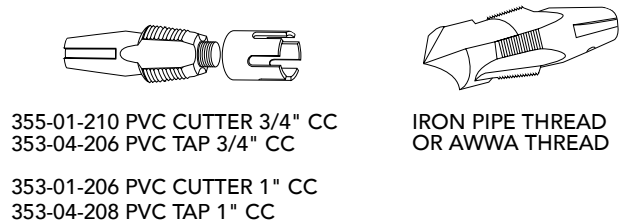

355-01-210 PVC CUTTER 3/4" CC  
 353-04-206 PVC TAP 3/4" CC  
 353-01-206 PVC CUTTER 1" CC  
 353-04-208 PVC TAP 1" CC

IRON PIPE THREAD OR AWWA THREAD